

# CSR REPORT 2014



### Corporate Motto

敬天愛人

Respect the Divine and Love People

Preserve the spirit to work fairly and honourably, respecting people, our work, our company and our global community.

### Management Rationale

To provide opportunities for the material and intellectual growth of all our employees, and through our joint efforts, contribute to the advancement of society and humankind.

### Management Philosophy

To coexist harmoniously with our society, our global community, and nature. Harmonious coexistence is the underlying foundation of all our business activities as we work to create a world of prosperity and peace.

### Business Management in Accord with the Kyocera Philosophy

In the corporate activities of KYOCERA Document Solutions, we share a common management rationale as a member of the Kyocera Group, and act in accord with the Kyocera Philosophy which is the foundation of our management.

The Kyocera Philosophy is a corporate philosophy that is rooted in the real-life experiences and empirical rules of the founder of the Kyocera Group, Kazuo Inamori, and emphasises the significance of commitment to fair management and operation, while upholding "doing what is right as a human being" as the principal criterion for business decisions.

We distribute the Kyocera Philosophy Handbook and the Kyocera Employee Action Guidelines to all employees, to encourage them to learn the Kyocera Philosophy and act responsibly as members of the company. In this way, we strive to ensure that employees learn and practice the Kyocera Philosophy by utilising these guidelines whenever they have an opportunity.

In the execution of business activities, we employ the two principal management tools—the Amoeba Management System (a small group-based management method) and Kyocera Accountancy (Kyocera Group's accounting principles), both of which have been developed to realise the Kyocera Philosophy.



KYOCERA Document Solutions Management Philosophy  
<http://www.kyoceradocumentsolutions.com/csr/philosophy.html>

## Editing Policy

---

### Regarding the CSR REPORT 2014

The CSR Report 2014 is published to report to all stakeholders on the CSR activities of KYOCERA Document Solutions, and thereby improve their understanding. The report focuses on topics of high importance to all of our stakeholders.

More detailed information is provided on our website.

<http://www.kyoceradocumentsolutions.co.jp/company/csr/index.html>

**Reporting Period** Activities and efforts reported are primarily those carried out in FY2013 (April 1, 2013 to March 31, 2014), however ongoing past efforts as well as recent activities are also featured.

**Published** October 2014

**Produced by** Corporate CSR Division, Corporate General Affairs Division, KYOCERA Document Solutions Inc.

## Corporate Overview

---

**Company Name** KYOCERA Document Solutions Inc.

**Headquarters** 1-2-28 Tamatsukuri, Chuo-ku, Osaka 540-8585, Japan  
Tel: +81-6-6764-3555

**President** Katsumi Komaguchi

**Founded** November 1934

**Established** July 1948: Mita Industrial Co. Ltd.  
January 2000: Name changed to KYOCERA MITA Corporation  
April 2012: Name changed to KYOCERA Document Solutions Inc.

**Capital** ¥12 billion (100% contributed by KYOCERA Corporation)

**Net Sales** ¥307.8 billion (year ended March 31, 2014)

**Employees** 15,833 (as of March 31, 2014)

**Business Description** Manufacture and sale of monochrome and colour printers, multifunctional products, wide format systems, document solutions, application software, and parts and supplies.

**Group Companies** 66 (including KYOCERA Document Solutions Inc.)  
(as of March 31, 2014)

(Capital and sales figures are rounded to the nearest ¥100 million.)

## CONTENTS

**02 Basic Approach to Management**

**03 Editing Policy**

**03 Corporate Overview**

**04 Top Commitment**

### Group's CSR Principles

**06 Group's CSR Activities**

**06 Participation in International Initiatives**

**07 Risk Management**

**07 Compliance**

**08 Corporate Governance and Internal Regulation System**

### Together with Suppliers

**09 Basic Approach to Purchasing Activities**

**09 Collaboration with Suppliers**

**09 Compliance with Conflict Mineral Regulations**

### Together with Customers

**10 Quality Assurance Efforts**

**11 Universal Design**

### Efforts to Protect the Environment

**12 Basic Philosophy of Environmental Management of the KYOCERA Document Solutions Group**

**13 Efforts in Product Development**

**13 Efforts at the Raw Material and Part Procurement Stage**

**14 Efforts at Production Bases and Offices**

**14 Efforts at the Distribution Stage (ECO Logistics)**

**15 Efforts at the Product Use Stage**

### Together with Society

**16 Social Contribution Activities of the KYOCERA Document Solutions Group**

**18 Business Overview**

# Supplying the best possible document solutions for each customer



The information society we live in is advancing and developing due to the widespread adoption of mobile information devices, cloud computing, etc. Due to the increasing need of customers to handle documents in any place at any time, their needs in regards to document devices are becoming more diverse.

Therefore, we should continue to offer quick and effective solutions to the problems that customers face in their respective document environments.

### **Aspiring to deliver new value to customer businesses and earn customer trust**

We supply value to customers for their document work, in the form of economical, environmentally-friendly printers and multifunctional products equipped with our long-life technology, and our extensive software portfolio that we have cultivated over many years. As a result, we now sell products in over 140 countries around the world, with directly managed sales offices in 31 of them.

In more recent years, we have focused on offering not only equipment sales and maintenance, but also have been actively developing a total solution service business. As a result, we have come to realise that increasing business productivity while reducing costs is currently a major issue for many customers. Therefore, we will take advantage of the extensive experience and expertise we have cultivated in global markets to offer a managed document service (MDS), which surveys and analyses customer document environments to propose optimal equipment layout, system installation, operation management, and perform ongoing system optimisation after installation. MDS will not only reduce paper and toner consumption, but will also reduce the time spent on crisis management and will improve business efficiency.

Therefore, we are committed to continuously improving our ability to resolve document issues and earn the trust of our customers as their business partner.

### **Living together - Promoting CSR activities globally**

As a member of the Kyocera Group, to "coexist harmoniously with our society, our global community, and nature (living together)" is the underlying foundation of all our business activities. Therefore, all of our activities are conducted based on our desire to continue progressing in harmony with people and society. In a Kyocera class offered at a public secondary vocational school in China, for example, students not only receive vocational training, but are also taught how to be responsible citizens that can make a positive contribution to society. At our Vietnam Plant, in addition to providing the workforce with manufacturing skills, we are also providing research and development skills by teaching local young aspiring engineers the advanced skills necessary to develop new products. We believe that by providing hope to the young people who represent the future of the country and supporting them to achieve their dreams, we are helping to promote the development of the country and the surrounding region.

In this way, we feel that our company should serve as a public institution that lives together with society by contributing to the progress of host countries and regions through our corporate activities, while also respecting the history, culture, customs, laws, and regulations of each respective country and region.

To achieve this commitment, we ensure that management practices are highly transparent and business activities are fair and honest. In addition, we are dedicated to further developing and promoting CSR activities by working together with local communities and employees on measures that contribute to society.

Through our reporting, we hope you will develop a better understanding of the CSR activities of KYOCERA Document Solutions.

**Katsumi Komaguchi**

President

# Group's CSR Principles

Under the corporate motto "Respect the Divine and Love People," our corporate group bases our management process on the philosophy of "Providing opportunities for the material and intellectual growth of all our employees, and through our joint efforts, contribute to the advancement of society and humankind."

We believe that the foundation of CSR activities is to build mutual trust with stakeholders, achieve continuous development of our company's business, and contribute to the sound development of society. This is achieved by carrying out management based on the Kyocera Philosophy, in which we make decisions by "doing what is right as a human being."

## Group's CSR Activities

While working to strengthen our corporate governance and other aspects of our management foundation, we carry out transparent management based on policies such as Kyocera Accountancy, Kyocera Employee Action Guidelines, and Amoeba Management.

Furthermore, we have positioned the Kyocera Group CSR Guidelines as our code of conduct for business activities aimed at bringing about a sustainable society, and deploy balanced CSR activities with an eye on economic, environmental and social benefits.

### Kyocera Group CSR Guidelines

Conceptual Diagram of CSR

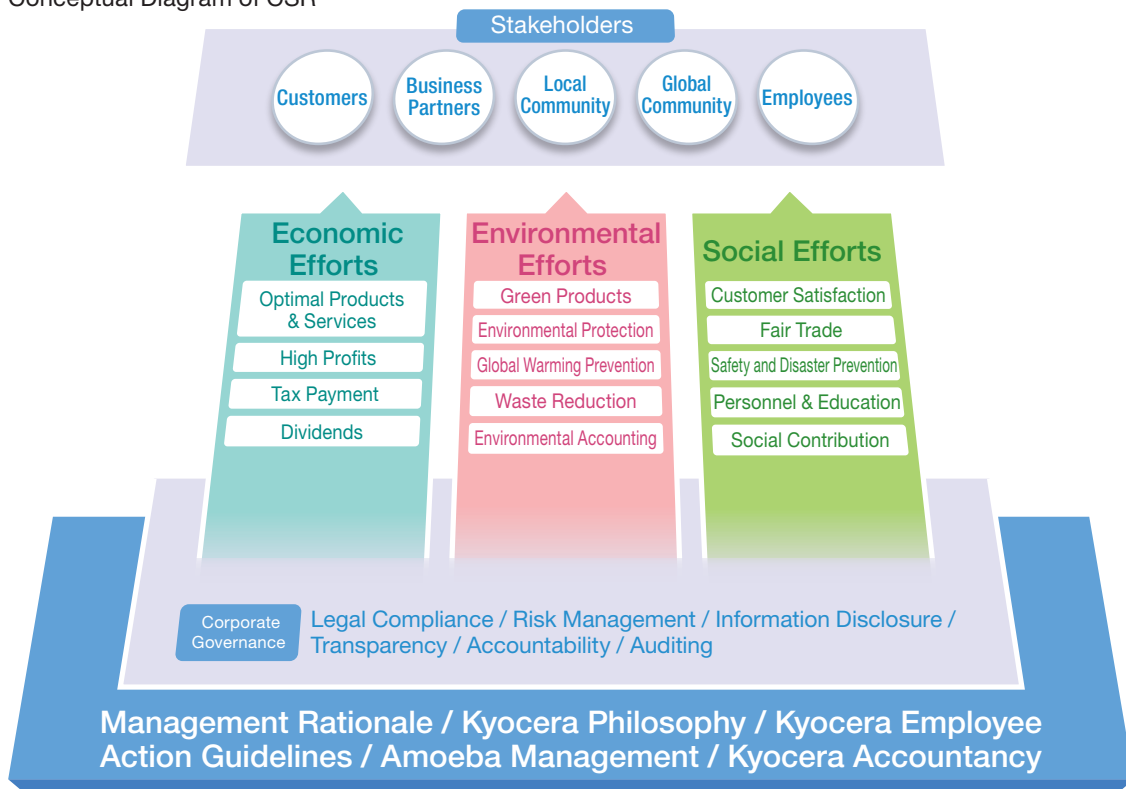

## Participation in International Initiatives

As a member of the Kyocera Group, our company carries out its CSR activities in accordance with ISO 26000, a standard prescribing the social responsibility of corporations. We also support the aims of the United Nations Global Compact, which sets forth 10 principles relating to issues including human rights, labour, the environment, and anti-corruption.



Network Japan  
WE SUPPORT

### Participation in International Initiatives

 Group's CSR Principles  
[http://www.kyoceradocumentsolutions.com/csr/about\\_csr.html](http://www.kyoceradocumentsolutions.com/csr/about_csr.html)

## Risk Management

In order to handle ever diversifying risks existing both within and outside of the company, the KYOCERA Document Solutions Group has developed a Risk Management System, and we

### || Risk Management Policy

To cope with ever more complex global risks, we are working to strengthen risk management throughout our entire group. Efforts are being made, centred on the Risk Management Department, to gather information and take countermeasures

### || Risk Management System

The risk management system of our corporate group operates under the President, who is the Chief Risk Management Officer, and is comprised of a full-time Risk Management Committee Chairperson, supervising executive officers, appointed employees in charge of risk management, and the Risk Management Secretariat. We have developed a system to enable prompt response by the Risk Management Department

### || Business Continuity Planning

Within our group, we are strengthening efforts to achieve continuous action for disaster prevention, and ensure business continuity so that we can continue to supply products and services to customers. In Japan, we are strengthening our initial response system in case of a large-scale earthquake or disaster, and developing a system which can stably supply products and services even if there are adverse effects on production due to factors such as interruption of electric power supply, and damage to production equipment.

work to forecast and prevent risks which may occur, as well as strive to minimise loss if a risk does occur.

beforehand for risks which may impact trust in our group or business continuity. These risks include large-scale disasters, environmental problems, information leaks, and unfair labour practices or violation of human rights in the supply chain.

and other related departments if a major event occurs or there are concerns that such an event may occur.

We have established internal company regulations such as management rules for important laws and regulations, and the Crisis Management Manual, which is designed to provide measures for emergencies and minimise losses, and we make these regulations available to all employees.

#### ■ Results in FY2013

1. By following our Incident Management Plan for scenarios such as large-scale earthquakes, we checked the disaster prevention system, fixtures and equipment at each business site, and also conducted nighttime disaster prevention drills.
2. In 2013, we conducted BCP drills at our Hirakata Plant in April, and our Tamaki Plant in May, in accordance with our overall BCP.

#### ■ Aim for FY2014

We will develop BCP measures assuming disaster risks appropriate for the regions of our overseas group companies.

## Compliance

As a member of the Kyocera Group, KYOCERA Document Solutions has established Kyocera Employee Action Guidelines as a code for employees, and we abide by all relevant laws inside and outside Japan. Our group works to ensure legal compliance in all our

### || Legal Compliance Efforts

#### Understanding and Dealing with Legal Information

In order to ensure compliance with new laws and revised laws, the law investigation department provides notifying information regarding new and revised laws to each department and the legal audit department audits the status of law and ordinance observance in each section regularly.

### || Secure Export Control and Trading Control System

To ensure compliance with the law in import and export transactions, KYOCERA Document Solutions maintains a system to cope with laws such as the Foreign Exchange and Foreign Trade Act and the Customs Act.

To ensure secure export control as stipulated in the Foreign Exchange and Foreign Trade Act, we carry out control based on KYOCERA Document Solutions Secure Export Control Regulations.

For import and export, we have acquired specified exporter

operations through efforts such as management by the department in charge of each respective law, development of an in-house notification system for when new laws come into effect or existing laws are revised, and implementation of periodic legal audits.

#### Legal Audits

Each department carries out a legal self-audit by following a legal checklist, and the legal audit department periodically carries out a legal audit of each department. In this way, our compliance system is constantly maintained and improved.

and specified importer authorisation from customs authorities, and conduct importing and exporting procedures pursuant to the control rules for business related to trading. We carry out secure export control and internal auditing of trade control, and have confirmed that the system is being properly maintained.

In FY2014, we will develop a secure export control system for our companies in charge of overseas regions, and will conduct education and self-audits.

## Corporate Governance and Internal Regulation System

As a member company of the Kyocera Group, KYOCERA Document Solutions realises the sound fulfilment of its Management Rationale, and fair, just, and highly transparent corporate governance based on the Kyocera Philosophy.

Corporate governance and internal regulation are implemented with the following system to ensure that directors' duties are executed in accordance with applicable laws, regulations, and articles of incorporation.

### Corporate Governance Body

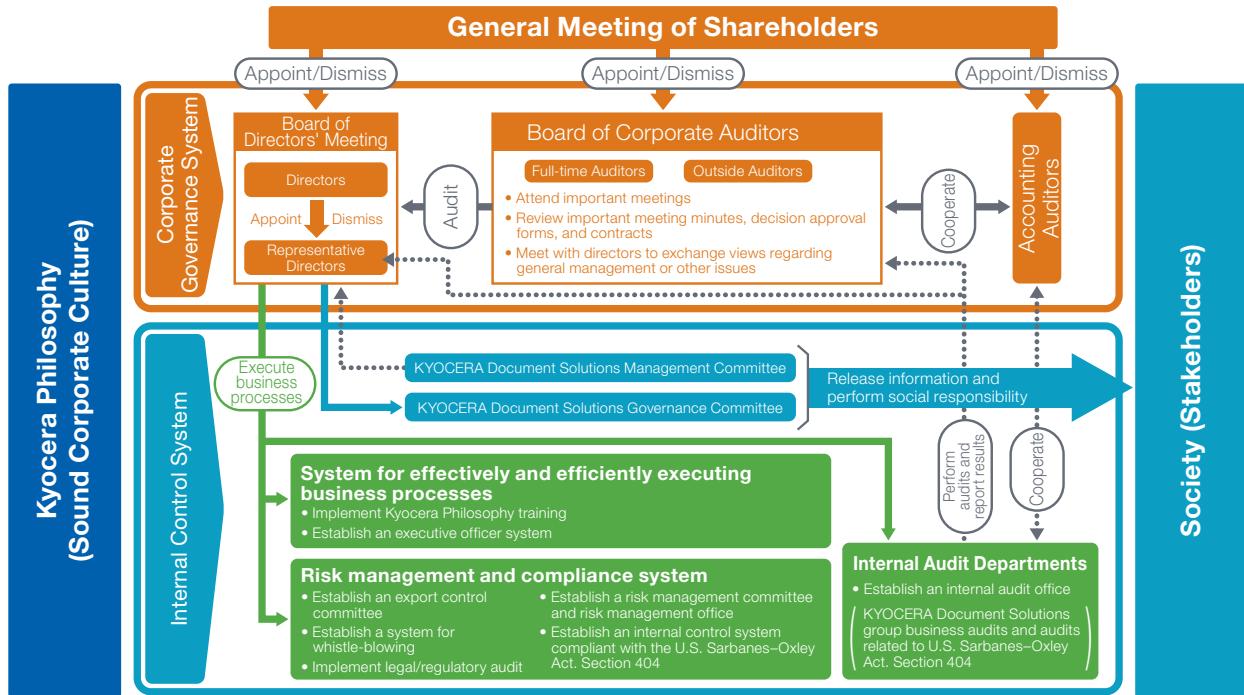

### Corporate Governance System

The directors responsible for the execution of business operations function under a corporate governance system to ensure the company's soundness and the fair and honest conduct of business. Our corporate governance body consists of auditors and a Board of Corporate Auditors. If any director discovers any violations of the law or breaches in the Articles of Association or any possibility of such occurring or any matters that could cause substantial detriment to the KYOCERA

Document Solutions Group, that director must immediately report the discovery to the Board of Corporate Auditors. Also, to ensure that audits by auditors are carried out effectively, directors must respond to any requests by auditors requesting attendance at important meetings, or the submission of materials for inspection such as important minutes of meetings, or contracts.

### Internal Regulation System

The directors responsible for the execution of business operations are developing our internal regulation system to carry out the management policy and master plan in a just manner and with the intent to realise our Management Rationale.

In concrete terms, they ensure the integrity of the internal regulation system through enforcing transparency in the assignment of jurisdictions and systems of responsibility within the executive officer system, as well as establishing and

operating the export control committee, risk management committee, risk management office and system for whistle-blowing.

The U.S. Sarbanes–Oxley Act has applied to the KYOCERA Document Solutions Group since April 2006. Therein, pursuant to this Act, we maintain an Internal Audit Department and receive internal regulation audits of financial reports conducted by external auditors.



# Together with Suppliers

In the KYOCERA Document Solutions Group, we are working to actively communicate with our suppliers, and focusing efforts on building partnerships based on trust.



## Basic Approach to Purchasing Activities

We have set forth matters such as legal compliance and environmental preservation activities by expressing our basic approach to purchasing activities as the "KYOCERA

Document Solutions Basic Purchasing Policy." When selecting suppliers, a precondition is that they understand and abide by our basic approach.

## Collaboration with Suppliers

Inside Japan, we are continually assessing the improvement situation regarding surveys of the state of CSR procurement promotion at our suppliers. (These surveys were started in FY2008.) This is carried out once a year for suppliers whose efforts are evaluated as inadequate, and we will continue these efforts going forward.

When starting a new business relationship, we provide the new

supplier with the KYOCERA Group CSR Guidelines, and the KYOCERA Document Solutions Supply Chain CSR Promotion Check List. We have new suppliers check the status of their own CSR promotion, and request self-directed improvement of any inadequate items. The same efforts are also being made at our Shilong Plant (China) and Vietnam Plant.

## Compliance with Conflict Mineral Regulations

The US financial regulation reform law (Dodd-Frank Wall Street Reform and Consumer Protection Act) makes it mandatory for companies listed on US stock exchanges to disclose the use in products of certain minerals which are a source of funding for armed groups engaged in inhumane acts. These include some of the minerals produced by the Democratic Republic of the Congo and surrounding countries (such as tantalite ore, tin ore, gold, tungsten ore and their derivatives). Since 2013, we have been working to comply with regulations on such conflict minerals, based on the Kyocera policy of not purchasing materials, products or other items which use these conflict minerals or metals derived from them. We have asked our suppliers to attend Kyocera Group meetings on conflict minerals held in Japan and in the Dongguan area of China. Here we explained our policy for dealing with this issue and asked for cooperation in conducting surveys. No involvement with conflict has been confirmed in the surveys which began in April 2013.

### TOPICS

#### CSR Procurement Efforts at the Vietnam Plant

At our Vietnam Plant, which began operation in September 2012, progress is being made toward local procurement of parts, and we are also increasing the number of suppliers. Compared with plants in Japan and China, the scale is still not very large, but on July 18, 2014 about 30 suppliers were invited to the Vietnam Plant, and a meeting was held to explain conflict minerals.

# Together with Customers

KYOCERA Document Solutions practices the "customer-first" principle throughout all processes of the product life cycle, from planning, development and manufacturing, to sales, use, support and recovery.



## Quality Policy

1. Our top priorities are the global environment and product safety.
2. We shall provide attractive products and services through "customer first" commitment.
3. We shall get it right the first time, and be a world quality leader.

## Quality Assurance Efforts

The Corporate Quality Assurance Division of KYOCERA Document Solutions conducts evaluation beforehand assuming conditions in the market as well as various types of reliability testing to ensure that our products always operate stably during use by the customer. Furthermore, we conduct verification tests based on the customer's actual usage environment. In addition, through market support, we listen to what customers say so that their feedback can be incorporated in new models. We also use the PDCA (plan-do-check-act) cycle for quality when manufacturing products. Our company is making the following efforts to strengthen our

### Reforming Evaluation Methods

Our Quality Assurance Department has the role of evaluating whether products are at a level where they can be sold in the market, correcting any problems discovered after sale, and working to prevent recurrence. The department previously evaluated quality based on past data and experience, but with previous techniques there were concerns that it would be impossible to respond to changing needs, and satisfy the needs of customers in countries throughout the world with different use conditions.

Therefore, before performing evaluation of newly sold products, each of the staff in charge of evaluation develops an understanding of the nature of new technology and design changes, operating requirements, and factors which affect mechanisms, and they examine evaluation content taking into account the situations where customers will use the product and the environmental

### Reforming Verification

We are working to innovate in the area of verification techniques. Previously, pass/fail judgment was made using the criterion of whether or not, based on evaluation standards, the product provides the function and performance described in product specifications. However, at present, we do not limit ourselves only to variation in performance at the time of mass

quality assurance system, so that we can provide even better products to our customers.

1. Reform reliability assurance processes to incorporate new evaluation methods and verification techniques aimed at prevention.
2. Reform manufacturing quality control by building quality into manufacturing processes.
3. To ensure products can be used with more confidence, improve the quality of service support in the market.
4. To better maintain quality, maintain and manage quality systems on an ongoing basis.

conditions of product use. After that, further discussions are held within the Quality Assurance Department regarding evaluation content, including issues likely to arise. By adding evaluation content incorporating perspectives deriving from the knowledge and imagination of all members, we carry out evaluation responsive to issues overlooked with previous criteria.

By conducting this sort of evaluation, we further strengthen verification of the quality of the sold product. We improve product reliability through prevention of potential problems in the development stage, before they occur, and thereby provide products which can satisfy the customer.



Discussion of evaluation content

production and measures to counter the causes of such variation. We also conduct verification incorporating the behaviour of parts while taking into account use conditions in the market.



Cassette endurance examination

## Reforming Information Gathering and Analysis

Our Market Support Team plays the important role of gathering information from sales companies all over the world. As a liaison for inquiries and malfunction information from sales companies, this team investigates and responds in collaboration with relevant departments. It is also in charge of promoting product quality improvement, and incorporation of improvements into the next model.

To eliminate delays in information gathering due to time differences and distances, the Market Support Team holds daily meetings with technical supervisors from the umbrella sales companies. By exchanging information directly with sales companies every day, the team responds to new issues from the initial stage, and this is useful for predicting trouble which may occur in the future, and initiating a response at an early stage. Problems which occur after a product has been released to the market are important reference information for product development and improvement. We gather and analyse market

data relating to product and service quality from all over the world, and provide feedback to the relevant departments. In order to effectively exploit these precious information resources, we gather data broadly from both inside and outside Japan. Through statistical analysis and text mining of this data, we are building a system for integrated analysis of quality risks and failure factors. By using the analysis data obtained from this system, we strive to continuously improve the quality of products and services. We also identify the latent needs of customers, and provide feedback for development of new products.

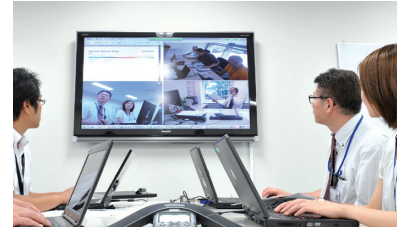

Meeting of sales companies inside and outside Japan using a teleconferencing system

## Universal Design

Taking advantage of Article 508 of the Rehabilitation Act (US), which came into effect in June 2001, we have raised interest in universal design and the importance of accessibility, and actively made efforts in these areas.

Universal design at our company is positioned as User Centered Design. The engineers and designers who develop our products use equipment such as wheelchairs and kits

that enable them to experience the world as senior citizens do. In this way, they start by themselves experiencing and understanding the perspective of persons with disabilities and the elderly. Those experiences give rise to a variety of ideas and new technologies, and these are then applied within our products.

### User Centered Design

#### Case 1 Easy-to-see, easy-to-read colour touch panels

Naturally, colour touch panels make lettering and other content easier to see and read, and it is possible to display thumbnails of read-in manuscript data and check their finished condition. In this and other ways, efforts have been made to improve ease of use by using a large screen.



#### Case 2 Operation buttons that can be identified by touching

Start keys, stop keys and the "5" keys of numeric keypads are equipped with a raised dot or bar for easy identification. A raised flange around the start key prevents mis-operation.



#### Case 3 Discharge tray makes paper easy to see

By making the printed paper discharge tray a deep navy blue, contrast with paper is increased, and this improves visibility of the discharged printed paper. Also, the tray shape is designed to make printed paper easy to remove.



#### Case 4 Colour schemes taking into account people with weak colour vision

By using colour schemes and designs that take into account differences in colour vision for operating panels, parts, and labels, etc., it is possible to accurately communicate information to people with different perceptions of colour vision.

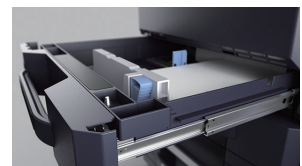

# Efforts to Protect the Environment

KYOCERA Document Solutions is working to reduce the environmental impact of our business activities, and reduce environmental impact throughout the product life cycle, in order to achieve the Environmental Vision established by the Kyocera Group.



## Basic Philosophy of Environmental Management of the KYOCERA Document Solutions Group

In 1991, the Kyocera Group established the "Kyocera Environmental Charter," setting forth our basic stance for addressing environmental problems based on the philosophy of "Living Together," and we began activities to protect the environment through a company-wide effort. As a member of the Kyocera Group, the KYOCERA Document Solutions

Group has established an "Environmental Vision" which puts the ideas of the Charter into concrete terms, and is engaged in environmental management that aims to achieve sustainable growth, while balancing ecology and economy, based on the "KYOCERA Document Solutions Group Environmental Safety Policy."

### Conceptual Diagram of Basic Philosophy

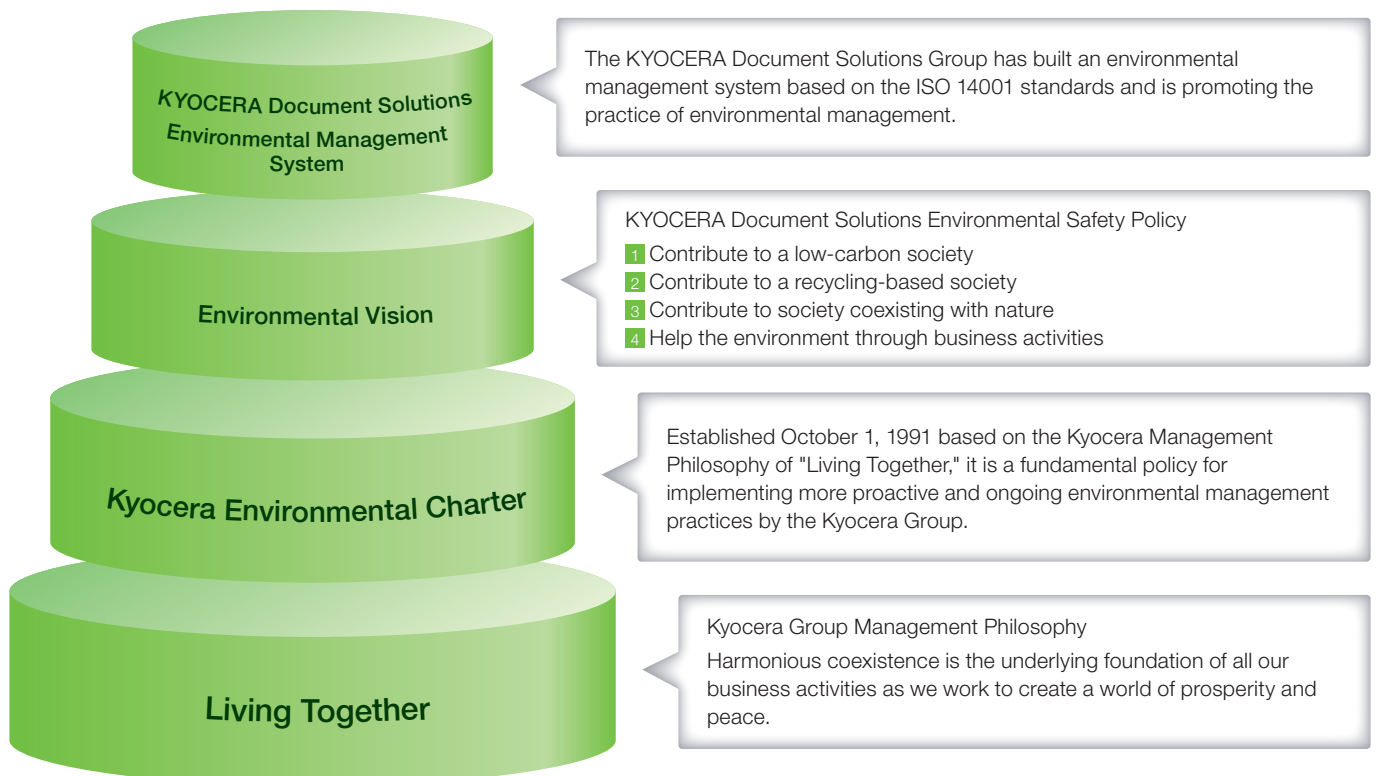

## Efforts in Product Development

### ECOSYS Concept

Since the release of our first ECOSYS printer, the ECOSYS FS-1500, in 1992, we have continued product development based on the ECOSYS concept, in which environmental impact is minimised by maximally extending the life of printer parts and thereby reducing part and supply waste (Ecology), and economic advantages are provided to the customer (Economy).

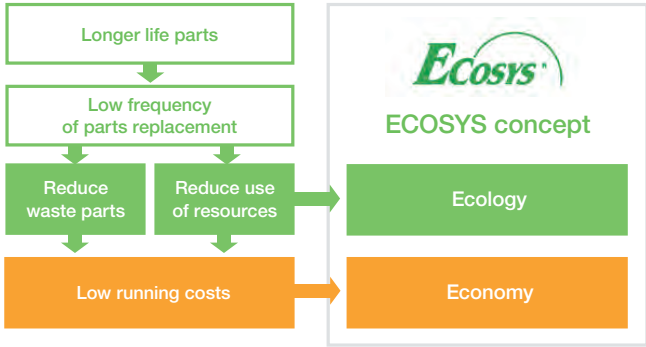

### Environment-Conscious Design

We employ designs that are environment-conscious from various perspectives for our products, including long-life design that helps reduce the amount of resources used, the frequency of part replacements and the amount of waste generated, "3R" design that emphasises "reduction," "reuse" and "recycling"

of components, low power consumption design that helps mitigate emissions of greenhouse gases, and elimination of specific chemical substances which may be contained in products.

## Efforts at the Raw Material and Part Procurement Stage

### Control of Chemical Substances Contained in Products

In order to create finished products that do not contain legally prohibited substances, an essential condition is that all parts, materials and auxiliary materials used in the manufacturing process must not contain prohibited substances. Our company investigates the contained chemical substances in all parts, materials and auxiliary materials, and we have X-ray fluorescence analysers installed in each of our plants to check that no hazardous substances are contained whose use is restricted by the EU's RoHS Directive.\* We also audit suppliers

to determine whether they have established chemical substance control systems ensuring that no prohibited substances are contained in their products, and we procure parts, materials and auxiliary materials only from suppliers who have acquired certification as a result.

To efficiently carry out chemical substance surveys, we introduced and have been using a chemical substance database since 2007, and this database is linked with core systems for engineering and production/materials.

\*Substances whose use is prohibited by the RoHS 2 Directive:  
The EU (European Union), as a rule, prohibits the sale of electric or electronic equipment containing the following six substances.  
(1) Lead, (2) Mercury, (3) Cadmium, (4) Hexavalent chromium, (5) Polybrominated biphenyls (PBB), (6) Polybrominated diphenyl ethers (PBDE)

### Efforts by KYOCERA Document Solutions to Control Chemical Substances Contained in Products

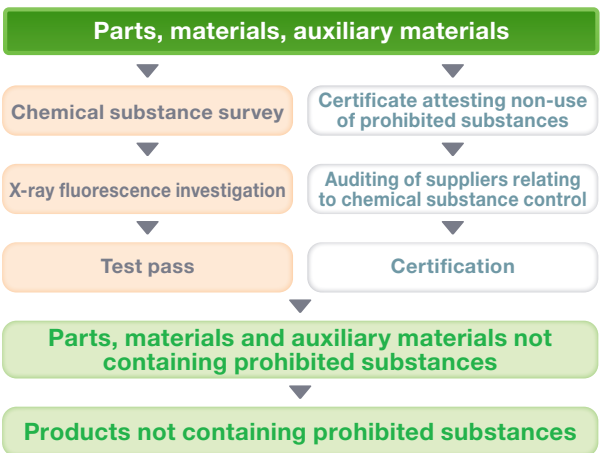

### Chemical Substance Control Database

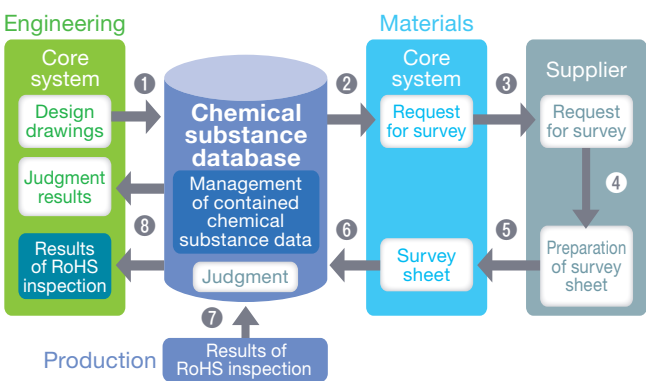

## Efforts at Production Bases and Offices

KYOCERA Document Solutions is working to implement a variety of energy conservation measures at our Japanese production bases and business establishments, with the target

of "reducing energy consumption per unit by an average of 1% a year, using FY2012 as the basis, and achieving a reduction of 7.73% or more in FY2020 from the FY2012 level."

### Promotion of Energy Conservation

#### 1. Energy Conservation Efforts

Carrying on from FY2013, we worked to make air conditioning equipment more efficient at each plant and business establishment in Japan by taking measures such as switching to high-efficiency models and installing sprinkler systems for outdoor units.

#### 2. Efforts to Reduce Peak Power

Since 2011 in Japan, we have been working to reduce peak power during the summer and winter at each of our plants and business establishments. In FY2013 too, we took energy conservation measures such as using thinning patterns for lighting, and reducing the number of operating elevators.

#### Energy Conservation Target and Progress

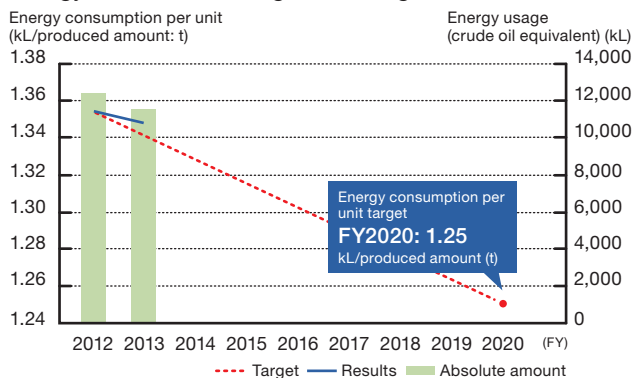

### Biodiversity Conservation

#### Implementation of Biodiversity Conservation Assessment at Offices

In FY2013, our business establishments at the Headquarters, Tokyo R&D Centre, and Tamaki Plant carried out a Biodiversity Risk Survey. The results indicated that, in all cases, our business activities were not having a major direct impact on the surrounding ecosystem, and we found almost no serious biodiversity risk requiring an urgent response. Outside of our business establishments, we are working to preserve the environment around the habitats of endangered stork species (Hyogo Prefecture), removing non-native species around Lake Biwa, and conducting clean-up activities to protect rare native species in the Matsunase tidal flats from non-native plants and drifting garbage (Mie Prefecture).



Volunteer clean-up activities in the tidal flats on the Matsunase coastline

## Efforts at the Distribution Stage (ECO Logistics)

Products produced at our Shilong Plant (China), our primary plant for multifunctionals and printers, have previously been transported mainly by truck to ports such as Yantian and Shekou in Shenzhen, loaded onto ships, and then shipped to various regions throughout the world. However, starting July 2012, we made a modal shift to rail for transport to the Port of Yantian, and as a result were able to reduce CO<sub>2</sub> emissions to 1/10th or less of their previous level. Products transported from our production bases to our European Distribution Centre (Beringe, Netherlands) are unloaded in Rotterdam Port, and we are promoting a modal shift to transportation by rail or river barge\* to the inland region of Beringe.

\*Barges: Small transport vessels that carry containers from ports to their destination using rivers and canals.

#### Usage Rates of Various Transport Modes from the Port of Rotterdam to Our European Distribution Centre: FY2013

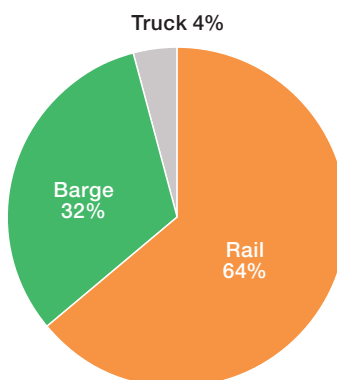

## Efforts at the Product Use Stage

KYOCERA Document Solutions implements life cycle assessment (LCA) on all its products in order to grasp the negative environmental impact of products over their entire life cycle and then reduce it.

### || Evaluation of Environmental Impact of Products

LCA is the method of visualising the overall environmental impacts of each product and service, by clarifying the numerical values of the amount of consumed resources, consumed energy and generated waste at every life stage of the product/service concerned, including "resources procurement," "production," "transportation," "use," "waste disposal" and "recycling."

This enables us to make objective evaluation of the effectiveness of our environmental action plans and achievements. We have acquired the EcoLeaf environmental label (the only Type III environmental label using the ISO standard-based LCA tool in Japan) for our products.

### || Environment-Consciousness of Products at the Usage Stage

#### New Fixing System Reduces Power Consumption Significantly

The ECOSYS FS-2100DN monochrome printer released in 2012 achieves 29% lower power consumption than previous models by adopting a "Heat-retention fixing system" for the fixing device, which typically consumes a large amount of power, and a power-saving controller.

#### Reducing Environmental Impact by Extending the Lives of Photoreceptor Drums

Starting with the colour printers and multifunctionals released in 2012, longer life has been achieved through the use of a newly developed photoreceptor drum. The service life of the new drum is 600,000 pages, which is twice the 300,000 page service life of the drum in the previous colour MFP model. Longer service life is achieved by using a harder and more durable a-C (amorphous carbon) type coating, with hardness close to that of diamond, to protect the surface of the previous a-Si (amorphous silicon) photoreceptor drum.

#### Consideration for the Office Environment "Ozone-Free Design"

Environment-consciousness is also an important issue in our customers' business environments. Our multifunctionals and printers employ photoreceptors which can be used with positive charge, such as a-Si (amorphous silicon) drums and PSLP organic photoreceptor drums. This reduces ozone generation to an almost undetectable level compared with previous charging systems.

Life Cycle Stages

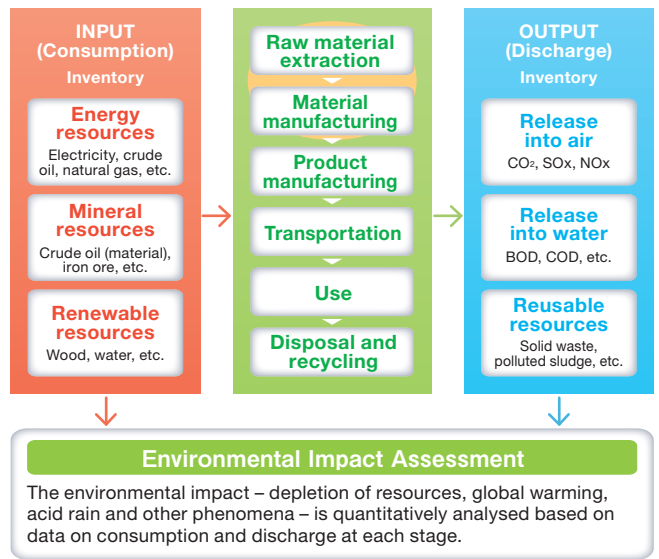

Cross-Sectional View of ECOSYS FS-2100DN Fixing Unit

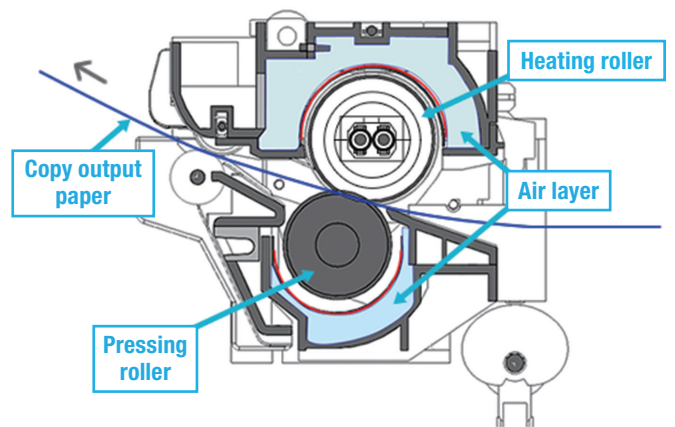

Long-Life Photoreceptor Drum Structure

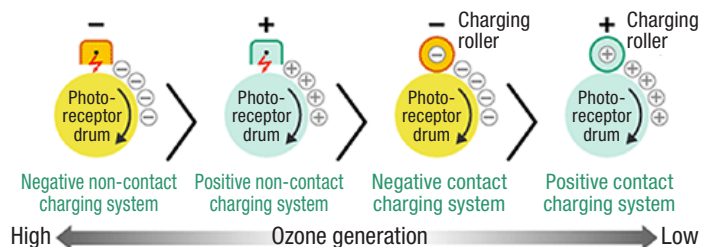
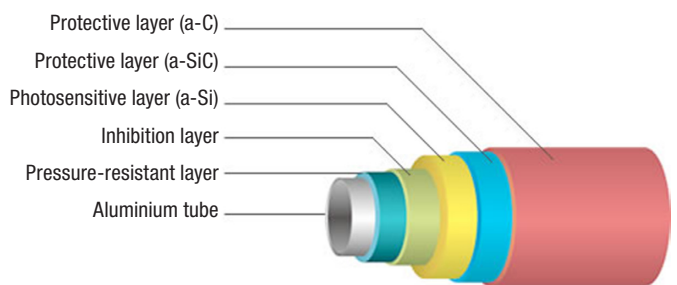

# Together with Society

The Management Rationale of KYOCERA Document Solutions is to contribute to the advancement of society and humankind while coexisting harmoniously with our society, our global community, and nature. All of our Group companies are engaged in measures to protect the environment and contribute to society based on our belief that these connections will enrich our hearts.



Thoughts on activities to contribute to society

## For the sake of children, the leaders of our future



**Masaki Kimura**  
General Manager,  
Corporate CSR Division

Based on our view that companies are a member of society, we want to play a more active role in solving the issues faced by particular regions and society as a whole. To achieve this end, we plan to effectively use all the resources made available to us and continuously contribute to society. It has now been eight years since we established our social contribution committee for the purpose of giving back to the regions and communities in which we operate and expressing our gratitude to the customers and trading partners that sustain our business to all those in the regions.

Our social contribution activities are conducted in a wide range of fields, such as activities to educate children, social welfare activities, environmental conservation activities, and humanitarian and disaster relief activities. However, our activities are primarily directed at educating children based on our desire to contribute to the healthy growth and development of the leaders of our future. Through these activities, we are able to experience the smiling faces and laughter of these children. Employees that participate can also grow, develop, and recapture a sense of motivation and purpose for their work.

All of our employees share in our commitment to continue these activities in order to contribute to society.

## Social Contribution Activities of the KYOCERA Document Solutions Group

### || KYOCERA Document Solutions Germany

#### Creation of the Kyocera Eco Award

In 2008, we established the Kyocera Eco Award together with the German Association for Small and Medium-sized Businesses (BVMW) and the German Environmental Aid Association (DUH). The purpose was to support the development of small- and medium-sized businesses in Germany and Austria, and encourage their contribution to the development of new energy conservation technologies and environmental protection projects. At the 4th Kyocera Eco Award held in Germany in January 2014, four companies—with distinguished achievements in four categories, including those related to biodiversity and environmental preservation—were selected through a strict screening process by judges including former German Minister of the Environment, Professor Klaus Töpfer.



Together with award recipients who participated in the award ceremony

### || KYOCERA Document Solutions United Kingdom

#### Supporting youth sports teams

KYOCERA Document Solutions United Kingdom supports eight youth football teams in different locations close to its UK offices. Playing team sports not only helps the children develop physically but also gives them an opportunity to learn important lessons about teamwork and fair play.



Giving children with dreams for the future playing kit featuring the KYOCERA Document Solutions logo



### KYOCERA Document Solutions South Africa

#### Ongoing support to an NGO that offers job training and assistance to disadvantaged people

We provide ongoing support to the NGO "Potter's House Training Centre." This facility serves people disadvantaged by Apartheid policies by offering basic education and training in the maintenance and repair of office equipment. For trainees that complete the one-year course and pass an examination, we act as a mediator to help them find work at our South Africa headquarters or at a dealer in neighbouring countries. We also donate money to cover the cost of operating the facility.



Providing various forms of support, such as job training and job assistance

### KYOCERA Document Solutions Australia

#### Participating in the Business Clean Up Day

Every year since 2000, KYOCERA Document Solutions Australia (KDAU) has participated as a corporate partner in Clean Up Australia. This is a clean-up campaign held throughout Australia, and sponsored by the non-profit organisation Clean Up Australia. In this campaign, participants can choose the area they want to clean up, and KDAU chose the area around a nature path in Christie Park, in the suburbs of Sydney.



Employees participating in volunteer cleaning activities

### KYOCERA Document Solutions America KYOCERA Document Solutions Development America

#### Participating in activities to give Christmas presents

Employees at the KYOCERA Document Solutions America headquarters, our sales subsidiary, raised donations from employees for toys to be donated to the Toys for Tots programme, sponsored by the U.S. Marine Corps Reserve. The San Francisco office of KYOCERA Document Solutions Development America, our product development centre in the United States, also participated in activities held by the NPO Family Giving Tree, which gives Christmas presents to the financially disadvantaged.



Christmas presents from the Family Giving Tree

### KYOCERA Document Solutions Tamaki Plant

#### Conducting the Kids' ISO 14000 Programme for the ninth consecutive year

At the request of Mie Prefecture and the Tamaki Board of Education, we conducted the Kids' ISO 14000 Programme at all four elementary schools in the town of Tamaki: Tokida, Tamuru, Uda and Shimotokida. This is a programme of activities for raising the problem awareness of children regarding the environment, so they become leaders in their homes and communities, and work to conserve energy and reduce waste. Through three classes, children improve their environmental awareness, and the course has been praised by parents and guardians for results such as encouraging children to diligently turn off lights at home.

These children are our future, and thus this effort makes a major contribution to environmental action in the home. We will continue this programme in the future.



Children becoming leaders to change their families' awareness

## Business Overview

We provide document solutions to over 140 countries worldwide through printers, multifunctionals and an extensive range of software technology produced based on our unique ECOSYS concept for "long-life" technology. With sales bases under our direct control in 31 countries, we have built a system which can provide detailed, close support to each individual customer.

### Sales Bases in the North, Central and South Americas

KYOCERA Document Solutions America Headquarters  
 KYOCERA Document Solutions Canada  
 KYOCERA Document Solutions Mexico  
 KYOCERA Document Solutions Brazil

### Sales Bases in Europe, the Middle East and Africa

KYOCERA Document Solutions Europe Headquarters (Netherlands)  
 KYOCERA Document Solutions Europe - Swiss Branch Office  
 KYOCERA Document Solutions Europe - Middle East Branch Office (UAE)  
 KYOCERA Document Solutions Germany  
 KYOCERA Document Solutions United Kingdom  
 KYOCERA Document Solutions France  
 KYOCERA Document Solutions Italy  
 KYOCERA Document Solutions The Netherlands  
 KYOCERA Document Solutions Belgium  
 KYOCERA Document Solutions Spain  
 KYOCERA Document Solutions Portugal  
 KYOCERA Document Solutions Austria  
 KYOCERA Document Solutions Russia  
 KYOCERA Document Solutions South Africa  
 KYOCERA Document Solutions Nordic (Sweden)  
 KYOCERA Document Solutions Nordic - Norway Branch Office  
 KYOCERA Document Solutions Denmark  
 KYOCERA Document Solutions Finland



## Production and Distribution Sites

### KYOCERA Document Solutions Shilong Plant (China)

Name of business establishment: KYOCERA Document Technology (Dongguan) Co., Ltd.  
 Address: Kyocera Industrial Park, 3 Fang Zheng East Road, Shilong Town, Dongguan City, Guangdong Province, China  
 Number of employees: 6,102 (as of March 2014)  
 Main product categories: Multifunctionals, printers and photoreceptor drums



### Kyocera Document Technology Shenzhen (China)

Name of business establishment: KYOCERA Document Technology (Shenzhen) Co., Ltd  
 Address: 2810-2811, Great China International Exchange Square, No.1 Fuhua Road, Futian District, Shenzhen City, Guangdong Province, China  
 Main business: Finding new parts manufacturing companies with bases in China and Asia, and providing technical support and quality control guidance



### Kyocera Document Technology Hong Kong

Name of business establishment: KYOCERA Document Technology Company (H.K.)  
 Address: 13/F., Mita Centre, 552-566 Castle Peak Road, Tsuen Wan, New Territories, Hong Kong  
 Number of employees: 136 (as of March 2014)  
 Main business: Shipment of products, procurement and shipment of service parts, procurement of production components





Europe Headquarters  
(The Netherlands)



Headquarters & R&D Centre  
(Osaka, Japan)



Asia Headquarters  
(Hong Kong)



Tokyo R&D Centre &  
KYOCERA Document Solutions  
Japan Headquarters



Czech Republic Toner Plant

## KYOCERA Document Solutions Headquarters

### Sales Bases in Asia and Oceania

- KYOCERA Document Solutions Asia Headquarters (Hong Kong)
- KYOCERA Document Solutions South Korea
- KYOCERA Document Solutions Hong Kong
- KYOCERA Document Solutions Taiwan
- KYOCERA Document Solutions Thailand
- KYOCERA Document Solutions Singapore
- KYOCERA Document Solutions India

### Head Office

<Sales Companies>

- KYOCERA Document Solutions Japan
- KYOCERA Document Solutions Australia
- KYOCERA Document Solutions New Zealand
- KYOCERA Document Solutions China

### Group Companies

- TA Triumph-Adler (Germany)

### R&D Sites

- KYOCERA Document Solutions Headquarters R&D Centre (Osaka, Japan)
- KYOCERA Document Solutions Tokyo R&D Centre (Tokyo, Japan)
- Chemical Products Development Centre, KYOCERA Document Solutions Tamaki Plant
- KYOCERA Document Solutions Development America (San Francisco & Los Angeles, USA)
- KYOCERA Document Solutions Development Philippines

### KYOCERA Document Technology Vietnam Plant

Name of business establishment: KYOCERA Document Technology Vietnam Co., Ltd.  
Address: Land Lots No. 56A, 56B and 56C, VSIP Hai Phong Township, Industrial and Service Park, Thuy Nguyen District, Dinh Vu-Cat Hai Economic Zone, Hai Phong City, Vietnam  
Number of employees: 945 (as of March 2014)  
Main product categories: Multifunctionals and printers



### KYOCERA Document Solutions Tamaki Plant (Mie, Japan)

Address: 704-19, Aza Matabe Nojino, Tamaki-cho, Watarai-Gun, Mie 519-0497, Japan  
Number of employees: 295 (as of March 2014)  
Main product categories: Consumables (colour toner, monochrome toner)



### KYOCERA Document Solutions Hirakata Plant (Osaka, Japan)

Address: 1-38-12, Tsudakita-cho, Hirakata-shi, Osaka 573-0121, Japan  
Number of employees: 231 (as of March 2014)  
Main product categories: Supply of devices to the US federal government (printers, multifunctionals), consumables (colour toner, monochrome toner, photoreceptor drums)  
Services provided: Storage and dispatch of products and parts





**KYOCERA Document Solutions Inc.**

1-2-28 Tamatsukuri, Chuo-ku, Osaka 540-8585, Japan

Tel: +81-6-6764-3555

Inquiries: Corporate CSR Division, Corporate General Affairs Division,  
KYOCERA Document Solutions Inc.

<http://www.kyoceradocumentsolutions.co.jp/>

Information in this report is as of October 2014.

©2014 KYOCERA Document Solutions Inc.